

Frontplattenausschnitt (Rückseite)
Panel cut out (rear side)

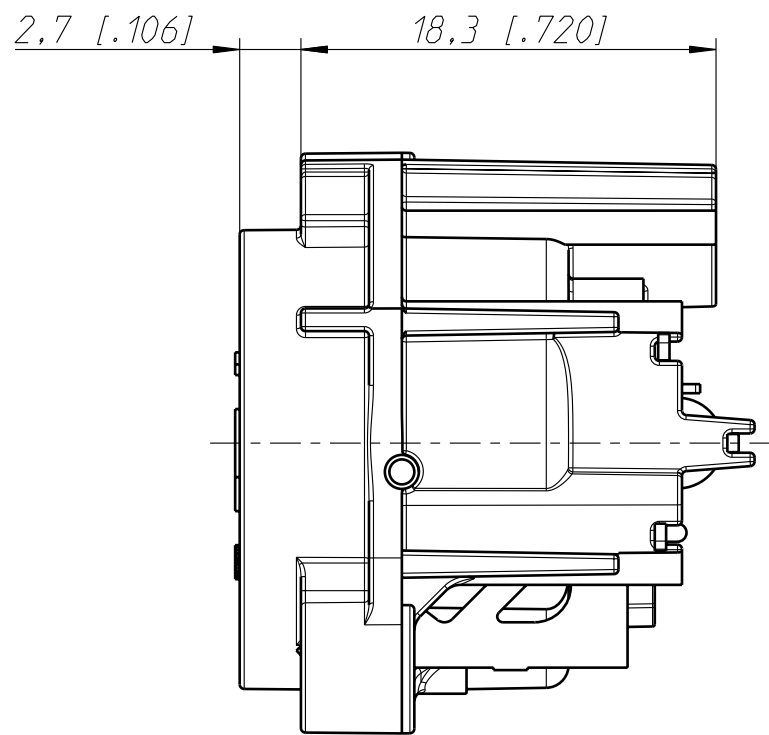

Print-Bohrplan (Bestückungsseite)
PCB-Layout (component side)

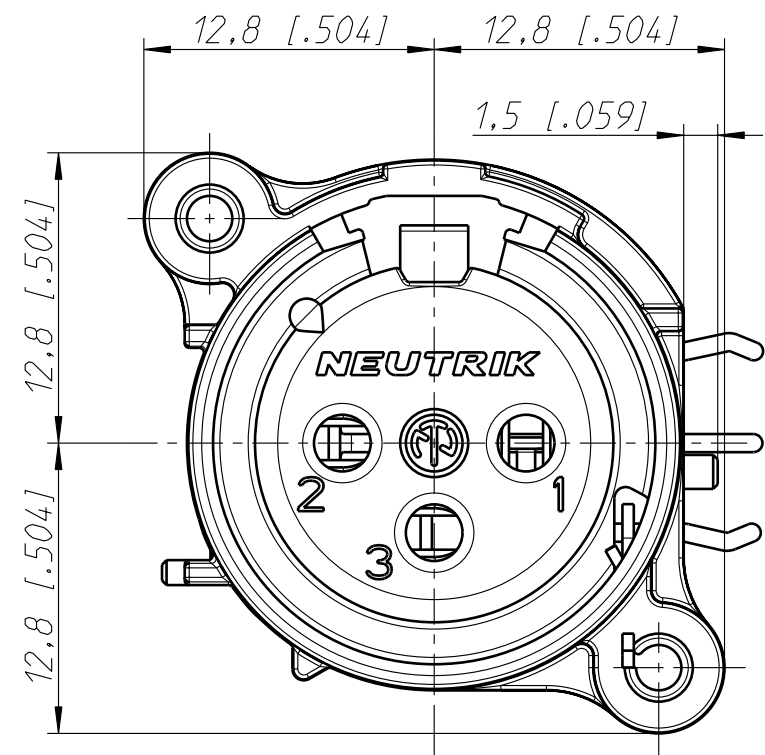

min. Einbauabstand
min assembling distance

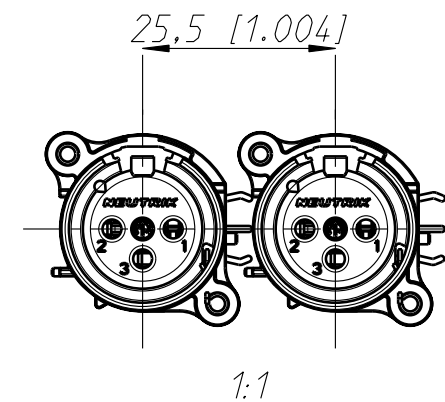
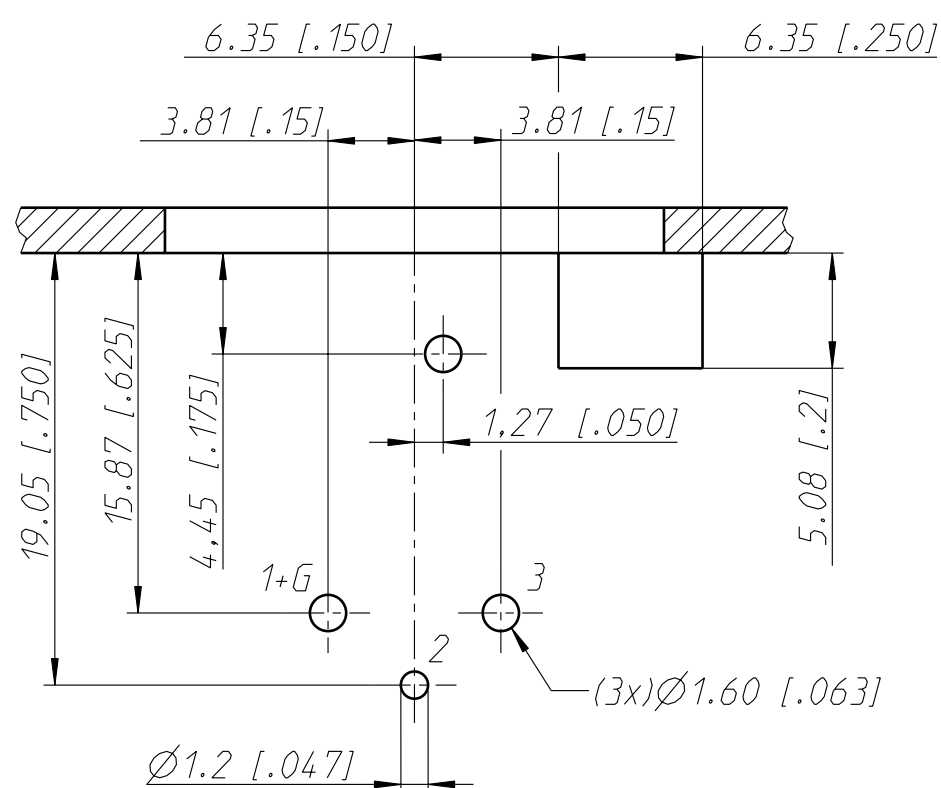
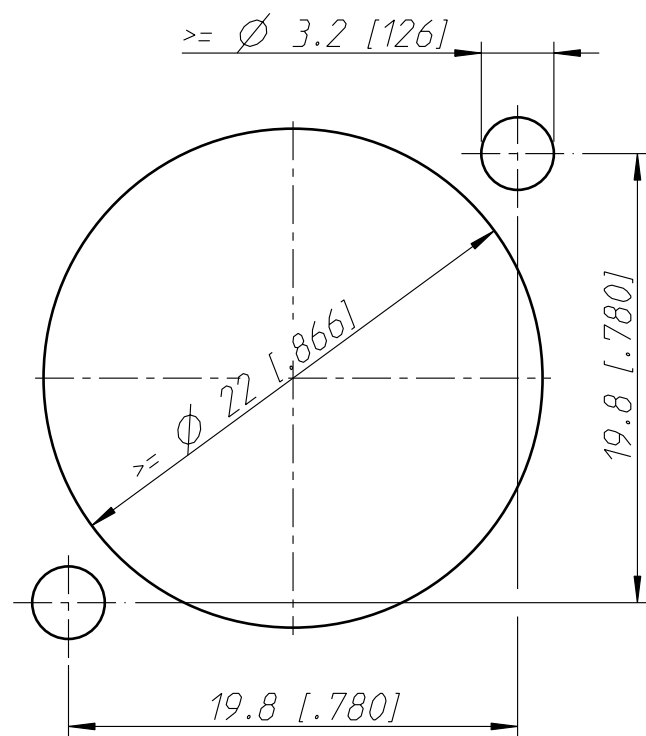

Layout tolerance $\pm 0.05\text{mm}$ (0.002")

Allgemeintoleranzen ISO 2768-m	Werkstoff	Massstab:	Datum	Name	
Zeichnung urheberrechtlich geschützt (DIN 34) (C)	-	3:1 (A3)	Gezeichnet	20.01.11	Karlinger
			Freigegeben		
			Geaendert	-	-
Benennung	-		Aend.-Nr.	Aend.-Index	
NC3FAHR1-0			Ersatz fuer:	Blatt 1 von 1 Bl.	
NEUTRIK AG FL-9494 SCHAAN			Zeichn. Nr.	ST-NC3FAHR1-0	